

1000B

Ultra-Stable Crystal Oscillator

KEY FEATURES

- Low Aging, 5.0E-11 Per Day
- Low Phase Noise, -160dBc at 10 kHz
- Independently Buffered Outputs
- Linearized Electronic Frequency Control
- Fast Warm-Up, 15 Minutes to 2.0E-8
- 0°C to 55°C Operating Temperature Range

Symmetricom's 1000B achieves low aging rates by utilizing high-performance SC-cut quartz crystal resonators. The specified aging is reached within 30 days of continuous operation, and typically continues to improve. Several users report observed aging rates as low as 1E-12 per day after years of continuous operation.

A dewar-insulated oven provides superior temperature stability over the full temperature range. The maximum frequency change over the operating temperature range is $<5E-9$. An oven temperature indicator (10mV per degree K) is provided at the power connector.

The oscillator circuit produces phase noise of -116 dBc at 1 Hz and -160 dBc at 10 kHz. Low noise, high isolation buffer amplifiers provide four independent outputs. The buffer amplifiers isolate outputs from load variations. An internal voltage regulator minimizes fluctuations due to power supply ripple.

Linearized electronic frequency control allows the use of servo loop techniques for fine frequency tuning. Linearity is better than 5% over the specified tuning range. The 1000B crystal oscillator meets the demands of a wide range of applications for military and industrial environments. The oscillator is found in precision frequency counters and synthesizers, GPS receivers, microwave multiplier chains, phase noise calibration test equipment, Stratum II telecommunications applications, radar and tactical communications systems, secure communications systems, satellite ground terminals and space flight systems.



1000B Ultra-Stable Crystal Oscillator

1000B SPECIFICATIONS

ELECTRICAL SPECIFICATIONS

- Frequency: (4) 5MHz
- Amplitude: (2) 1Vrms, (2) 0.5 Vrms
- Harmonic distortion: <-40dBc
- Spurious signals: <-80dBc
- Short term stability:
 - 1s <1.0E-12
 - 10s <1.0E-12
- Aging per day (see note 1) (after 30 days of operation) <1.0E-10
- Phase noise [-dBc/Hz]:
 - 1 <-116dBc
 - 10 <-140dBc
 - 100 <-150dBc
 - 1000 <-157dBc
 - 10kHz <-160dBc
 - 100kHz <-160dBc
- Temperature coefficient: <1.0E-9
- Frequency adjustment range
 - Tuning slope: Positive
 - Control range: 0 to 10V
- Load change (50Ω +/-10%) <5.0E-11
- Input voltage
 - Oven supply: 18 to 30VDC
 - Electronics supply: 18 to 30VDC

ENVIRONMENTAL & PHYSICAL SPECIFICATIONS

- Supply sensitivity
 - 1% change in input <1.0E-11
- EMI susceptibility (side bands)
 - 0.1Vrms on power supply inputs
 - 10 Hz to 104 Hz <-100dBc
- Temperature
 - Operating: 0°C to 55°C
 - Non-operating: -40°C to 85°C
- Power requirements
 - Warm-up: <13W
 - Operating at 25°C: <3.5W
- Warm-up to 2.0E-8 of final frequency: <15 minutes
- Oven monitors temperature: 10mv/C
- Dimensions: 3.0"W x 6.54"D x 3.0"H
- Weight: <1.5lbs (0.67kg)
- Connectors
 - RF (J1 - J4): SMA
 - Power (J5): 9 pin D-subminiature

ORDERING INFORMATION

- 1000B with (4) 5MHz outputs

Part No.

05818-103

Note 1: Aging typically improves to a level of parts in 1E-11 per day (1E-8/year). After years of unperturbed operation, some users have observed aging rates as low as 1E-12.

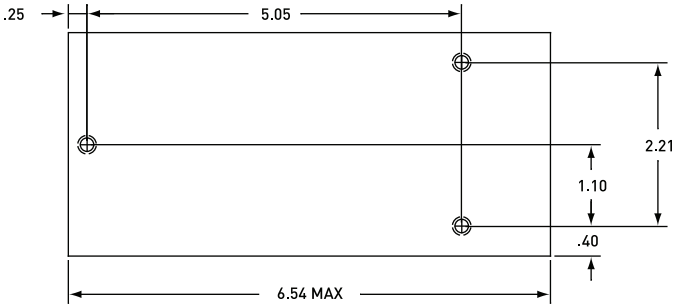

Bottom View

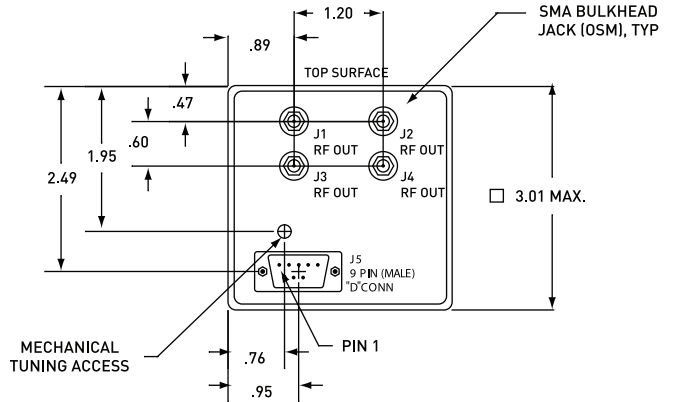

Front View



SYMMETRICOM, INC.
 2300 Orchard Parkway
 San Jose, California
 95131-1017
 tel: 408.433.0910
 fax: 408.428.7896
info@symmetricom.com
www.symmetricom.com