

**1000 VDC and Peak AC
Input-to-Output and
Channel-to-Channel
Isolation**

Supports Seven TC Types

**Built-In Open TC
Detection**

**High Accuracy and
Resolution Design**

**Extremely Wide CJC
Range**

Built-in RS-422 Interface

**Optional USB and RS-232
Adapters**

DATAQ Instruments' DI-1000TC Series products are a line of instrumentation modules designed for temperature measurements using thermocouples. The unit is provided in 4- or 8-channel versions, and each channel may be configured in software to support one of seven thermocouple types: J, K, T, E, S, B, or R. Temperature measurements may range from -200°C to $+1820^{\circ}\text{C}$ (-328°F to $+3308^{\circ}\text{F}$), depending upon thermocouple type. Each DI-1000TC thermocouple channel features a panel-mounted, miniature spade connector, and all input channels are electrically isolated from ground and each other up to 1000VDC or peak AC.

Model DI-1000TC is designed for use across the entire spectrum of temperature measurement applications. Its small size and wide measurement range make it a perfect temperature measurement device for laboratory applications. Its isolation feature allows it to be used in more demanding industrial applications that experience the large common mode voltages (off-ground measurements) that are typical of grounded thermocouples. Such measurement situations will prevent non-isolated instruments from making a measurement at best, or destroy them in the worst case.

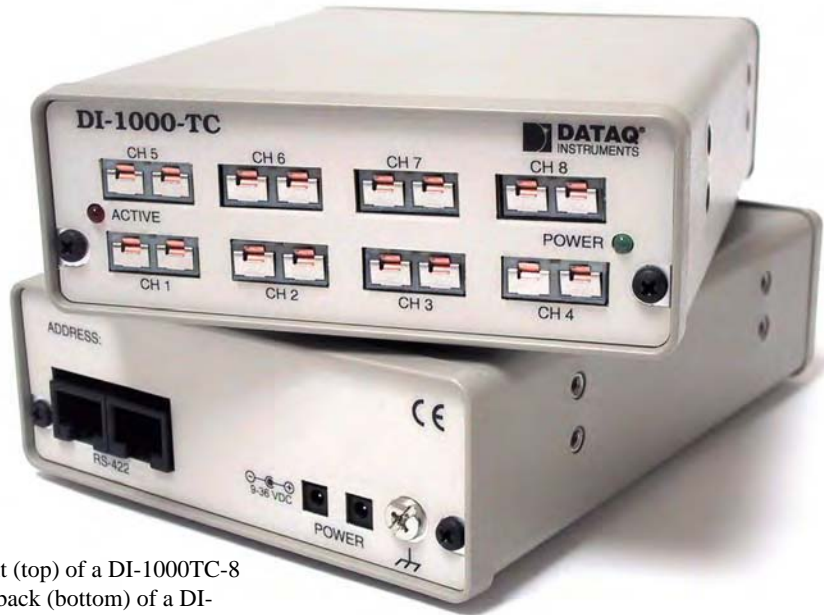

Front (top) of a DI-1000TC-8 and back (bottom) of a DI-1000 Series Instrument.

Features

Expandable

Multiple DI-1000TC units may be connected individually or used as expansion units with any combination of other DI-1000 instruments to address any application-specific situation. For example, multiple DI-1000TCs may be connected to each other to provide unique twelve, sixteen, twenty, or other channel counts. DI-1000TC products may also be mixed and matched with other DI-1000 instruments to yield unique measurement configurations that feature various input types (e.g. simultaneous TC, strain, digital I/O, and voltage) all with sample synchronization.

Built-in RS-422 Interface

The built-in RS-422 interface allows DI-1000TC units to connect to any host PC through an inexpensive adapter via an RS-232 or USB port. This RS-422 interface also serves as an expansion port for other DI-1000 Series instruments.

Isolation

The DI-1000TC's 1000VDC and Peak AC input-to-output and channel-to-channel isolation allows grounded TC measurements.

High Accuracy and Resolution Design

Allows sharpened decisions with an overall accuracy of $\pm 0.2\%$ of span, and temperature resolution as fine as 0.08°C .

Portable

Like all DI-1000 Series instruments, the DI-1000TC is provided in a small (13.81D x 10.48W x 3.81H centimeters; 5-7/16D x 4-1/8W x 1-1/2H inches) enclosure consisting of an aluminum base and all-steel wraparound.

Primary Customers

Those who need a PC-based temperature measurement instrument for laboratory or classroom use. Examples include physics, chemistry, biology, and any other discipline that requires accurate and ready-to-run temperature measurements. Those who require a rugged and flexible device for temperature measurements in industrial settings where off-ground measurements are common. Specific applications are temperature measurements in:

- Steel and aluminum smelting operations
- Annealing operations
- Hydraulic pumps, fluids, and motors
- Steam, gas, and hydraulic turbines
- Machine tools
- Motors and generators
- Rolling mill machinery and equipment
- Electric and gas welding and soldering equipment
- Industrial and commercial fans and blowers and air purification
- Industrial process furnaces and ovens
- Induction heaters
- And many, many more

Specifications

Number of Channels: Configurable as 4 or 8 channel modules within one enclosure

Supported Thermocouple Types: J, K, T, E, S, B, R - mix and match as required

Thermocouple Input Connectors: Panel-mounted miniature spade, universal TC-type

Temperature Range and Accuracy: See table below.

Open TC detection: An open thermocouple forces the channel to minus full scale.

Cold Junction Sensors: One for every group of 4 or 8 channels, depending upon configuration

Cold Junction Compensation Range: -40 to 125°C

Linearization: Accomplished transparently by the software driver to deliver scale temperature values to the host program.

Input Impedance: >1MΩ

Input Current: <0.05μA

Input Offset Voltage: <5μV

Maximum Normal Mode Voltage: 250VDC/Peak AC momentary; 50VDC/Peak AC continuous

Maximum Common Mode Voltage: 1000VDC or Peak AC

Common Mode Rejection: >160db @ 50 and 60Hz

Channel-to-Channel Isolation: 1000VDC or Peak AC

Input-to-Output Isolation: 1000VDC or Peak AC

Channel-to-Channel Cross Talk Rejection: >160db

Temperature Coefficient: <0.040μV/°C

Digital Filtering: 256-tap comb filter per channel, decimating

Voltage Range: -10mV to 50mV

Expansion Capabilities

Method: Via integral RS-422 port to other DI-1000 Series modules

Max. Sample Rate from Expansion

Units: 5 samples/second/channel

Maximum Distance: 4,000 feet

Scanning Characteristics

Maximum Sample Rate: 5 samples/second/channel

Minimum Sample Rate: 0.55 samples/hour/channel

Scan List: 9-position, 8 positions may be programmed for channel number and TC type; ninth position reserved for CJC access

Synchronization: Digital via expansion port to synchronize multiple modules

Sample Buffer: 36 samples

Calibration

Calibration Cycle: One year

Calibration Method: Calibration constants are stored within each module's EEPROM. Provided calibration software to automate calibration in the field.

RS-422 Interface

Supported Baud Rates: 9600 (default), 19200, 38400, 56800, 115200

Data Bits: 8

Stop Bits: 1

Parity: None

Handshaking: ModBus protocol

Connector: RJ-45

General

Panel Indicators: Power and Active LEDs

Operating Environment: -40 to +85°C

Enclosure: Aluminum base with steel wrap-around. Aluminum end-panels with plastic bezels.

Dimensions: 5-7/16D x 4-1/8W x 1-1/2H inches 13.81D x 10.48W x 3.81H centimeters

Weight: 20 oz. (8-channel version)

Power Requirements: 9 to 36 VDC, 1 watt

DI-1000TC Block Diagram

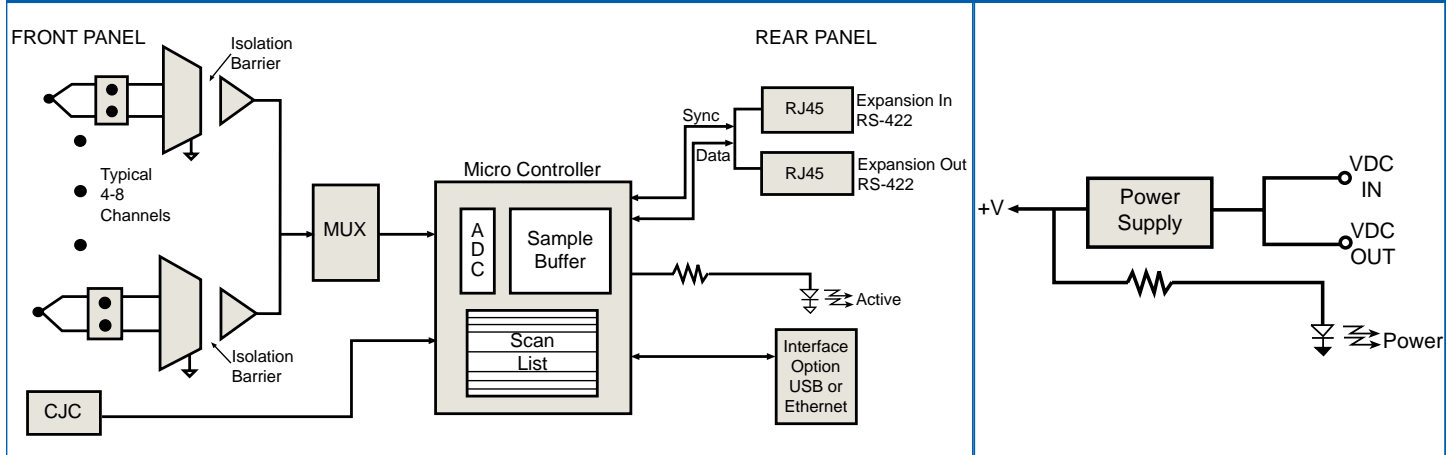

Temperature Range and Accuracy

TC Type	Range	Accuracy*	Resolution**
J	-200 to 870°C	±0.3%	0.1°C
K	-200 to 1230°C	±0.2%	0.1°C
T	-200 to 400°C	±0.5%	0.08°C
E	-200 to 660°C	±0.3%	0.2°C
S	-200 to 1760°C	±0.4%	0.4°C
B	-200 to 1820°C	±0.6%	0.5°C
R	-200 to 1760°C	±0.4%	0.4°C

*25°C ambient temperature; excludes CJC errors; excludes TC errors. Value shown is a percent of full-scale range.
 **Resolution is for temperatures above 0°C.

Ordering Guide

Description	Order No.
4-channel DI-1000TC	
4-channel DI-1000TC with RS-422 interface, for temperature measurement using thermocouples.	DI-1000TC-4
8-channel DI-1000TC	
8-channel DI-1000TC with RS-422 interface, for temperature measurement using thermocouples.	DI-1000TC-8
USB to RS-422 adapter	DI-1000-USB
RS-232 to RS-422 adapter	DI-1000-232



241 Springside Drive
 Akron, Ohio 44333
 Phone: 330-668-1444 Fax: 330-666-5434
 www.dataq.com